



The most complete Unit Exchange program available in the industry!

Quality

All of IAE Power Products' exchange components meet or exceed OEM specifications for optimum life cycle cost. This is one of the **IAE Power Products UTEX Advantages.**

Service

The IAE Power Products Rebuilt Unit Exchange program is the fastest and most economical way to significantly minimize downtime. Another **IAE Power Products UTEX Advantage.**

Experience

IAE has been serving the railroad industry since 1947. We are a Woodward authorized, full service facility with complete parts supply and rebuilding capabilities. We are proud of our history as a key player in the growth of ADS, the prestigious Association of Diesel Specialists. Once again a great **IAE Power Products UTEX Advantage.**

EMD

| New Part# | UTEX# | Description |
|---|-----------|---------------------|
| GOVERNORS | | |
| Varies with engine application | | Woodward |
| GOVERNOR DRIVES | | |
| 8175893 | 40085329 | |
| SOAK BACK & FUEL PUMPS | | |
| 8498154 | 8498154 | 1.7gpm (f) |
| 8498155 | 8498155 | 1.7gpm (s) |
| 8080284 | 8296349 | 4gpm\1200rpm (f) |
| 8422951 | 40061420 | 6gpm\1200rpm (f) |
| 8498156 | 8498156 | 3gpm (s) |
| FUEL PUMP MOTORS | | |
| 5540387 (C974) | 8296358 | 1/4 hp\1200rpm |
| 4947308 (C994) | 40013526 | 3/4 hp\1200rpm |
| FUEL PUMP & MOTOR ASSEMBLY | | |
| 8080384 | 8296428 | 1/4 HP\4gpm |
| 8302492 | 8296428 | 1/4 HP\4gpm |
| 8425609 | 40044270 | 3/4 hp\6gpm\1200rpm |
| SOAK BACK PUMP & MOTOR ASSEMBLY | | |
| 8492180 | 40009239 | 3/4 hp\3gpm |
| 8152343 | 8379234 | 1/4 hp\1.7gpm |
| 567 & 645 INJECTORS WITH NEW TIP | | |
| 5228540 | 8477971NT | |
| 5228565 | 8477972NT | |
| 5229200 | 8478045NT | |
| 5229250 | 8478046NT | |
| 5229290 | 8478048NT | |
| 5229295 | 8478049NT | |
| 5229310 | 8478051NT | |
| 5229320 | 8478053NT | |
| 5229335 | 8478055NT | |
| 5229500 | 9081163NT | |
| 5229510 | 9081164NT | |
| 5229710 | 9333858NT | |



| New Part# | UTEX# | Description |
|------------------------------------|------------|-------------------------|
| 710 INJECTORS WITH NEW TIP | | |
| 5226700 | 9565086NT | |
| 5227285 | 40028663NT | |
| 5227000 | 40027607NT | |
| STARTERS | | |
| 1990333 | 8384834 | 32VDC |
| 1993740 | 8428605 | 64VDC |
| 1993743 | 1993743 | 64VDC with 64V solenoid |
| AIR COMPRESSORS | | |
| All Gardner Denver 3 & 4 cylinders | | |
| WATER PUMPS | | |
| Part# | UTEX# | Left/Right Bank |
| LOW CAPACITY | | |
| 8058624 | 9516925 | LEFT |
| 9516119 | | |
| 40004236 | | |
| 8058625 | 9516924 | RIGHT |
| 9516120 | | |
| 40004237 | | |
| MEDIUM CAPACITY | | |
| 8269638 | 9503461 | LEFT |
| 9336390 | | |
| 8269664 | 8296348 | RIGHT |
| HIGH CAPACITY | | |
| 8347607 | 9332825 | LEFT |
| 9320244 | | |
| 9530407 | | |
| 40004234 | | |
| 8249002 | 9510677 | RIGHT |
| 9530406 | | |
| 9501979 | | |
| 40004235 | | |



| New Assembly Part# | Unit Exchange Part# | Application |
|---|---------------------|--|
| LUBE OIL SCAVENGING PUMPS | | |
| 8042376 | 8122883 | All 6 & 8 cylinder roots blown engines |
| 8041928 | 8122885 | All 12 cylinder roots blown and 8 cylinder turbocharged engines |
| 8042375 | 8122886 | All 16 cylinder roots blown and 12 cylinder turbocharged engines |
| 8262903 | 8296459 | All 567 & 645 16 cylinder turbocharged 20-645, 12-710 engines |
| 8429304 | 40000226 | 16-710 engines |
| LUBE OIL PISTON COOLING & PRESSURE PUMPS | | |
| 8106919 | 8122947 | All 12 cylinder roots blown and 8 cylinder 645 turbocharged engines |
| 8084556 | 8122949 | All 16 cylinder roots blown 567 & 645 and 12 cylinder 645 turbocharged engines |
| 8252844/9330012 | 8296366 | All 16 cylinder 567 & 645 turbocharged engines and 12-710 engines |
| 8360554/9330013 | 8427270 | All 20 cylinder 645 engines and 16-710 engines |

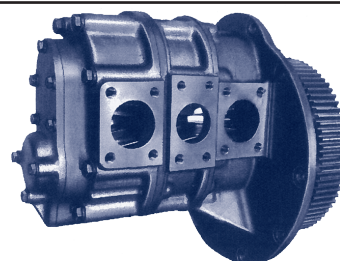

GE

| UTEX# | Manufacturer |
|-----------------------------|-----------------|
| FUEL PUMPS | |
| 132X1535 | Bendix |
| 132X1645 | Bryce |
| 132X1710 | Bryce 18mm |
| FUEL PUMP CONVERSION | |
| From: | 132X1254 Bendix |
| To: | 132X1535 Bendix |
| GOVERNORS | |
| Woodward | |
| INJECTOR CONVERSION | |
| From: | 123X1041 Bendix |
| To: | 123X1110 Bryce |
| INJECTORS EXCHANGE | |
| 123X1110 | Bryce |

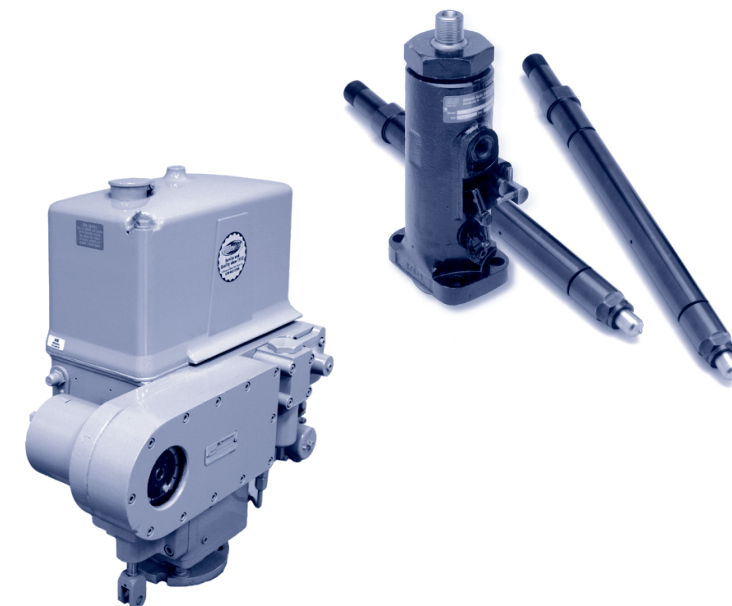

AVAILABLE IN QUARTER 2000